

DAE 1535 Integrated extractor unit

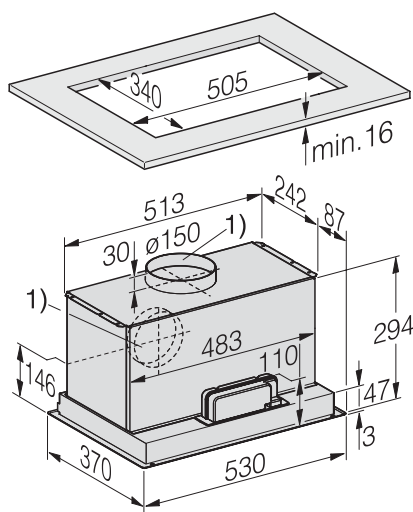

- Customised kitchen design – fully integrated in 532 mm width
- Powerful – 400 m³/h at the highest level
- LED strip for uniform lighting
- Efficient filtration – 10-layer stainless-steel grease filter
- Safe and easy to clean – Miele CleanCover

DAE 1535 Installation diagram



- 1) Exhaust air connection alternatively to the rear., Exhaust air connection Ø 150 mm., Further detailed dimensions can be found in the operating instructions!

EAN: 4002516879954 / Material number: 12760970

Construction type	
Integrated extractor	•
Appliance colour	
Stainless steel/Clean Steel	•
Operating modes	
Type of air guide	Can be retrofitted
External operation	–
Recirculation conversion kit (order separately)	DUU 150, DUU 151
Active charcoal filter (order separately)	DKF 32-P
User convenience	
Miele@home	–
Con@ctivity 3.0	–
Controls	EasySwitch
Run-on time 5/15 min.	–
Grease filter saturation indicator	–
Active charcoal filter saturation indicator	–
Efficiency and sustainability	
Energy efficiency class	–
Filter system	
Stainless steel grease filters	1
Lighting	
Number x W)	1 x 3.2 W
Light intensity in lx	360 lx
Colour temperature in K	3500 Kelvin
Blower	
DC motor	–
Extraction	
Air throughput in Level 3 (m ³ /h)	400
Noise level in Level 3 dB(A)	60.0
Sound pressure Level 3 dB(A)	46.0
Recirculation	
Air throughput in Level 3 (m ³ /h)	400
Sound power Level 3 dB(A)	65.0
Sound pressure Level 3 dB(A)	51.0
Safety	
Safety switch-off	•
Technical data	
Overall rangehood height for extraction mode in mm	330
Overall rangehood height for recirculation in mm	–
Canopy dimensions (W x H x D) in mm	532 x 330 x 372
Min. clearance above electric cooktop in mm	600
Min. clearance above gas cooktop in mm	650
Voltage in V	230
Fuse rating in A	10
Total rated load in kW	0.24
Installation notes	
Extraction ducting connection at top/rear	• / •
Ø of exhaust connection in mm	150
Con@ctivity with compatible cooktop	–