



Sirius

KIARA RANGE

SL906XDTM850

850MM EXTRA DEEP ONBOARD UNDERMOUNT



SPECIFICATIONS

Rangehood Type	Undermount
GTIN	9351116006075
Country of Origin	Hand-Crafted in Italy
Suits Cooktop Size	600-900mm
Suits Cooktop Style	Induction, Electric, Gas
Recommended Install Height	min 600 - max 750mm from cooktop surface
Finish	Stainless Steel
Controls	Touch Buttons
Speed Settings	4 (3 + Booster)
Recirculating	No
Extraction Rate	2200m ³ /h
Filter Type	2 x Baffle
Noise Level*	approx. 45dBA to 73dBA
Lighting	6W Dynamic Lighting
Run-on Timer	Yes
Automatic Shut-Off	Yes
Electrical Requirement	10AMP
Max Current (W)	556W
Motor Options	Twin Onboard Green Energy
Ducting Options	Top & Side
Ducting Size	200mm diameter
Product Dimensions (mm)	H472 x W850 x D360
Nett Weight	25kg
Carton Dimensions (mm)	H480 x W865 x D400
Gross Weight	30kg
Warranty	3 Years - 6 Years if paired with Sirius Ducting
Energy Rating [^]	A
kWh/Annum [^]	approx. 46

LINE DRAWING

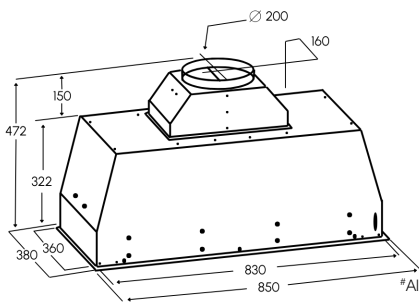

Cut-out Dimensions[#]
W835 x D360mm

Dimensions include trim.
*Allows upto 5mm extra for ease of installation.
See user manual for more information.

KEY FEATURES



Green Energy Twin Motor

Double the efficiency with our Twin Green Energy Motors. The perfect choice for open-plan kitchens with powerful extraction of steam, smoke, odours and grease. Our Green Energy design offers significant energy saving without compromising on performance.



Powerful Airflow

With impressive airflow and control, this rangehood quickly and effectively removes smoke, steam, heat, odours, and other airborne particles from the kitchen. Conveniently controlled with 4 speed settings.



Dynamic Lighting

Adjust the lighting to suit your needs with our Dynamic Lighting System (DLS) with the flexibility to match the rooms lighting by adjusting the Kelvin between 2700 to 6500 or dim to set the mood. Also adjustable with the Sirius App.



Extra Deep Coverage

Ensuring ultimate extraction over your high-performance cooktop, the Extra Deep range gives you superior coverage. With a cleaner and more efficient cooking environment, all grease, odours and airborne particles are captured with the additional front to back coverage.



Baffle Filters

Interlocking C-shaped baffles capture grease and smoke. Highly regarded for their advanced design and durability, their leading construction is designed to catch oil, grease and other contaminants. With a lifetime warranty, they clean effortlessly in the dishwasher.



Slimline Design

Seamlessly hiding away in your kitchen cabinet make with a powerful extraction to remove steam, smoke, odours and grease. It's the perfect design for any kitchen design without compromising on functionality or style.



Induction Suited

This rangehood has the sufficient extraction required to facilitate induction cooking. As induction cooking uses the base of the pan as the heat source, less moisture and steam is evaporated before it reaches the filters. This can create drops of water that drip into your cooking.



Hand-Crafted in Italy

Quality, functionality, innovation, style & luxury hand-crafted in Italy. Leading the market in design and functionality, this collection has been specifically handpicked for Australian living.

*Note noise level is an approximate range and subject to installation and surrounding materials.

[^]Product is manufactured in Italy, ratings are based on European directive 65/2014 regulations.

This information is correct at time of producing and subject to change as products develop. Always check the physical product before making any cut-outs or installing.

For more information, visit our website.



Sirius

KIARA RANGE

SL906XDTM850

850MM EXTRA DEEP ONBOARD UNDERMOUNT



DUCTING OPTIONS

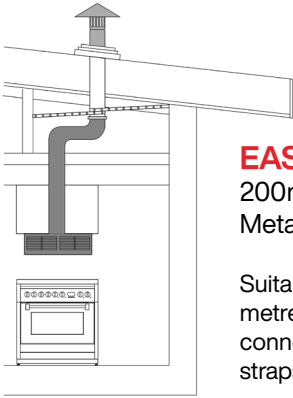

EASYROOFKIT

200mm diameter
Metal/Tiled Roof Installations

Suitable for duct runs of up to 4 metres, semi-rigid, solid duct, internal connectors, clamps, flashing, bracing straps and galvanised cowl included.



EASYEAVEKIT

200mm diameter
Eave Installations

Suitable for duct runs of up to 3 metres, semi rigid, clamps 125/150 expander and eave vent included .



EASYWALLKIT

200mm diameter
External Wall Installations

Suitable for duct runs of up to 3 metres, semi rigid, clamps 125/150 expander and wall vent include.

All EasyKits can be extended with 1 set (2) Universal Ring Clamps (URC25-215) and 1 x Semi Rigid Duct length (SRPRO30-150) that expands upto 3 metres.

6 Year Warranty

when Sirius ducting is used

Sirius has its own range of ducting kits and components, designed to get the most power and efficiency out of its hoods. The full range of high quality, cost effective ducting kits and individual parts will provide you with the best result for your rangehood.

Visit our website for more information on Sirius Rangehoods, SEM Motors and Sirius Ducting and EasyKits

