

**Series 4, Built-in microwave oven with hot air, 60 x 45 cm, Black CMA583MB0B**



**The built-in microwave for the 45 cm niche: use it for extra fast thawing, heating and perfect preparation of foods.**

- **AutoPilot 15:** perfect results with 15 pre-set automatic programmes.
- **Microwave function:** time-saving preparation, defrosting and reheating of dishes.
- **Hotair function:** even results on one level thanks to optimal heat distribution.
- **Stainless steel interior:** easy to clean interior thanks to smooth surfaces and no sharp edges.
- **Cleaning Assistance:** less cleaning effort thanks to the new cleaning option, which can be especially used for cleaning of light soiling.

Additional function: ..... Microwave combination  
 Color / Material Front: ..... Black  
 Built-in / Free-standing: ..... Built-in  
 Door opening: ..... Handle  
 Door colour: ..... Black  
 Cleaning : .....Hydrolytic  
 Control Panel Material: ..... Glass  
 Dimensions (HxWxD): ..... 454x594x570 mm  
 Dimensions of the packed product (HxWxD): .....550x670x700 mm  
 Required niche size for installation (HxWxD): ....450-452 x 560-568 x 550 mm  
 Cavity dimensions: .....220 x 420 x 420 mm  
 Cavity capacity: .....44 l  
 Max. microwave power level<sup>1</sup>: ..... 900 W  
 Number of interior lights: ..... 1  
 Net weight: .....35.3 kg  
 Gross weight: ..... 39.9 kg  
 EAN code: .....4242005279524  
 Connection rating: ..... 3350 W  
 Fuse protection: .....16 A  
 Voltage: .....230-240 V  
 Frequency: ..... 50 Hz  
 Length electrical supply cord: ..... 150 cm



<sup>1</sup> Intelligent inverter technology: maximum output power will be regulated to 600 W when used in longer operation

## **Series 4, Built-in microwave oven with hot air, 60 x 45 cm, Black CMA583MB0B**

568 mm x 550 mm

- Please reference the built-in dimensions provided in the installation drawing

### **The built-in microwave for the 45 cm niche: use it for extra fast thawing, heating and perfect preparation of foods.**

#### **Microwave and heating methods**

- Built-in Microwave with hot air function with the heating functions: Microwave, 5 power levels, Hot Air Standard, Hot air grilling, Full width grill, Pizza setting
- Max. Power: 900 W; 5 Microwave power settings: 90 W, 180 W, 360 W, 600 W, 900 W
- Temperature range 40 °C - 230 °C
- Grill 1750 W
- Grill and microwave power levels 90 W, 180 W, 360 W, 600 W combinable
- Microwave can be used separately or in combination
- Cavity volume: 44 l

#### **Design**

- stainless steel cavity

#### **Cleaning**

- Cleaning Assistance (manually)

#### **Convenience**

- LCD-display control (white)
- Electronic clock/timer with end time programming
- Rotary control knobs, Retractable control knobs, Touch control
- User-friendly electronics: extremely easy and comfortable operation
- AutoPilot, 15 automatic programs
- 4 defrost and 3 cooking programmes in microwave function, 8 programmes for combination function
- Fast pre-heating function
- LED light
- 36 cm Metal turntable
- Stainless-steel fan
- Bottom hinged door
- Bar handle
- Touch key operation

#### **Accessories**

- 1 x grid high, 1 x grid flat, 1 x turntable

#### **Safety Features**

- Child lock, Automatic safety switch off function, Door contact switch
- Integrated cooling fan

#### **Technical Information**

- Length of mains cable: 150 cm
- Total connected load electric: 3.35 KW
- Nominal voltage: 230 - 240 V
- Appliance: 454 x 594 x 570 mm

#### **Dimensions**

- Appliance dimensions (HxWxD): 454 mm x 594 mm x 570 mm
- Installation dimensions (HxWxD): 450 mm - 452 mm x 560 mm -

**Series 4, Built-in microwave oven  
with hot air, 60 x 45 cm, Black  
CMA583MB0B**

Measurements in mm

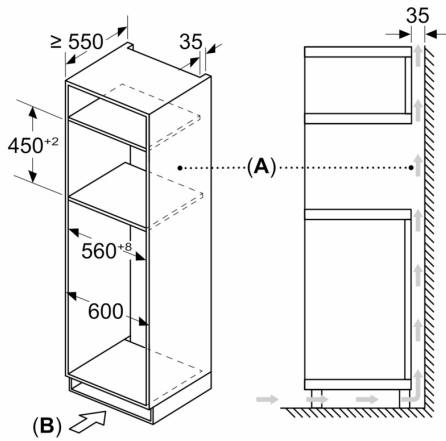

**A:** Back wall open

**B:** Ventilation space in the plinth  $\geq 100 \text{ cm}^2$

Measurements in mm

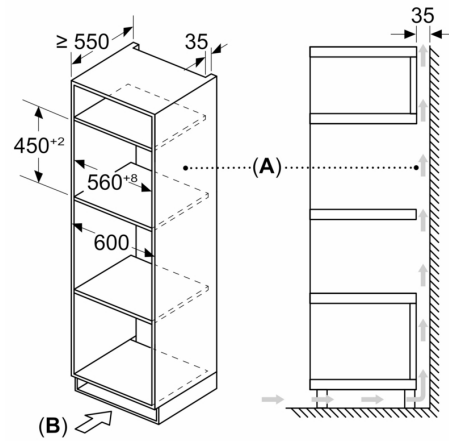

**A:** Back wall open

**B:** Ventilation space in the plinth  $\geq 100 \text{ cm}^2$

Measurements in mm

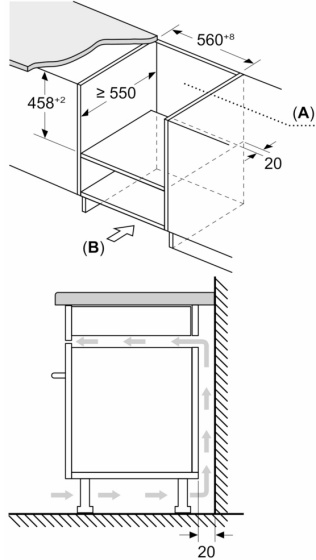

**A:** Back wall open

**B:** Ventilation space in the plinth  $\geq 100 \text{ cm}^2$

Measurements in mm

