

Billi Home BA with Multifunction Mixer Tap

The Home BA Boiling and Ambient (still) drinking water system, is a residential sized system, that maintains Billi's core design principles of space saving and vent-free installation. Offering both boiling temperature water and a bottomless supply of filtered ambient temperature water, the Home BA is convenient and highly functional.

The Good Design Award winning integrated Multifunction Mixer Tap provides a sleek solution to dispensing filtered water with a touch sensitive interface, alongside domestic mains supplied by operating a standard flick mixer.



BOILING



STILL

Features



AUSTRALIAN
DESIGNED &
MADE



SPACE SAVING
DESIGN



VENT-FREE
INSTALLATION



ECO-
INTELLIGENCE
ENERGY MODES



UNLIMITED
FILTERED
WATER



EASY
INSTALLATION

Multifunction Mixer Tap

Home BA Under-Bench Unit



Finishes

Standard Finishes



CH -
Chrome BR -
Brushed MB -
Matte Black MW -
Matte White

Special Order Finishes



UB -
Urban Brass GM -
Gun Metal Grey SB -
Sable Bronze

Add the relevant Finish Code to the Product code to complete your specification eg 914000LCH-LF

Accessories

990720 - Tubing Extension Kit for X series dual temp dispensers 2mtrs

Product Specifications

Water Type	BA
Dispenser	G - Multifunction Mixer Tap
Mixer Tapware	N/A
Product Code	914000G
Warranty	3 years manufacturers warranty
Under-Bench Dimensions	180mm(W) x 340mm (H) x 365mm (D)
Boiling Output	Up to 90 cups per hour
Chilled Output	N/A
Sparkling Output	N/A
50°C Hot Water Output	N/A
Min / Max Dispenser Temp	Ambient / 99°C
Power Plug	10 amp
Power Rating	1600W, 220-240V ~ 50-60Hz
Water Pressure	Min. 250kPa
Ecolabel	N/A
EPD	N/A
Greenstar Contribution	N/A
Watermark License	WM-021525
Lead Free	✓
Section J7.7 (NCC)	✓
WELS	N/A
WELL	Cornerstone Membership
Management Systems	Every Billi drinking water appliance is manufactured under the strictest standards and is certified in accordance with: ISO9001 for QMS (FS 790754), ISO14001 for EMS (EMS 801468) and ISO45001 for OSHS (OHS 801469).
Food Handling	HACCP License No. PE-138-BIL-R1-02
Filtration	994052 - 0.2 Micron supplied standard

Scan the QR code access
our Revit families on
bimstore

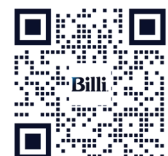

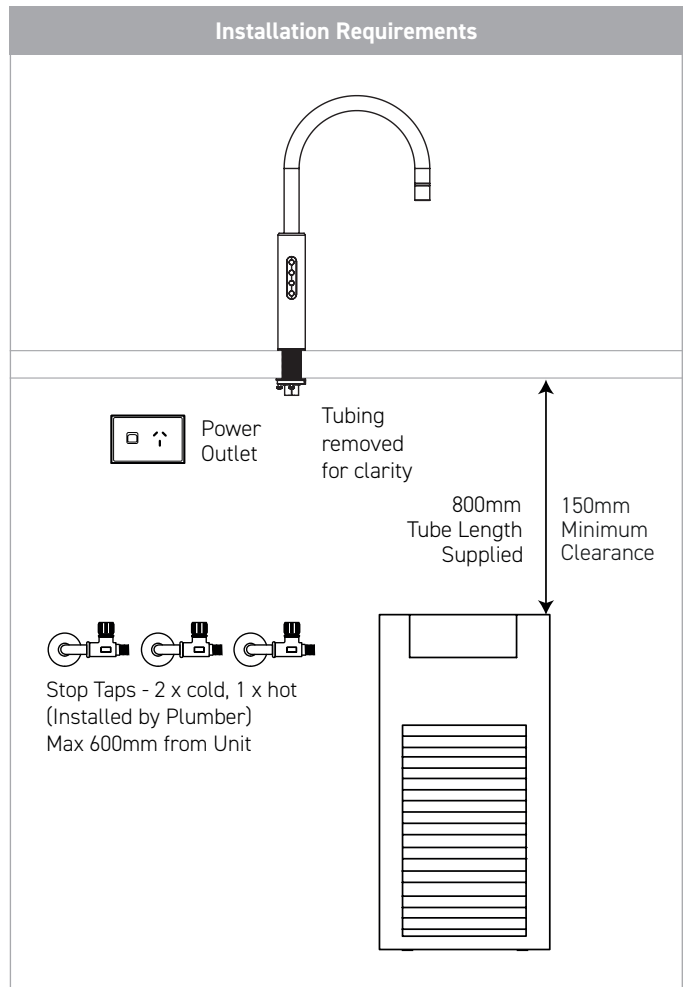
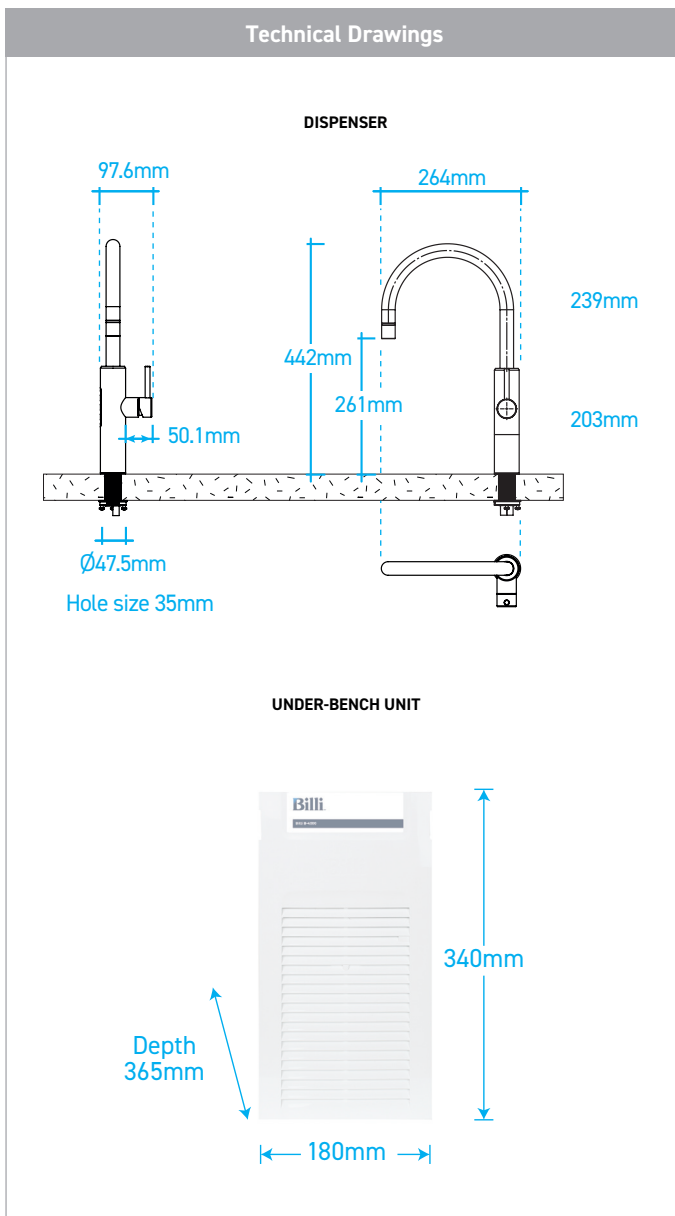

Installation Notes

Electrical	A standard 10 amp power outlet is required, located no further than 1000mm from the underbench unit. The system is supplied with a 1 metre flex cord and plug.
Water	1 x 1/2" BSP (15mm) cold stop tap required for unit supply and 1 x 1/2" BSP hot stop tap and 1 x 1/2" BSP cold stop tap required for mixer connection with male threads and it should be installed in an easily accessible position. Water supply must be microbiologically safe to drink, with a minimum dynamic water pressure of 250kPa and a maximum of 1000kPa.
Pressure Valve	Integrated 500kPa pressure limiting and dual check valve is pre-installed to the unit inlet.
Stone Benches	Billi has a no-cut policy regarding all stone benches in compliance with regulations. The safety of our team and customers remains Billi's top priority.
Ventilation	No joinery ventilation or accessories are required for this Billi product (no waste heat).

Filtration – Most Recommended Replacement Filters

Billi range of premium filters utilize BWT's unique FibronX® technology, providing superior taste, water quality, filter life longevity and peace of mind when it comes to hygiene.

994052 - (0.2 micron)

Supplied standard. Residential or Critical Care sites.

994051 - (5.0 micron)

Commercial & high volume sites.

*Drawings are for guidance during Specification, refer to Installation requirements for final install. All efforts are made to ensure Compliance & Certifications claims are current, however this is subject to change without notice. Billi assumes no liability or responsibility for out of date information.



Technical support

Book a service call

Filtration & service

Warranty registration

Please scan the QR code for all support information.

Billi Australia Pty Ltd
P 1800 812 321
W www.billi.com.au

Billi New Zealand Ltd
P 0800 636 0 636
W www.billi.co.nz

Billi®